

# Lost Tablets by Jan van Schaik

*Lost Tablets* are a limited series of unique objects by Jan van Schaik. They express a tension between the grammar of monumentality and a globally recognisable children's toy.

Limited to a total of 100, 85 *Lost Tablets* have been made over the past three years. The remaining 15 are currently in production – due for completion in early 2023.

“The *Lost Tablet* is a testament to [the] skill of seeing connections.”

Nikos Papastergiadis — Director of the Research Unit in Public Cultures, University of Melbourne



Each *Lost Tablet* includes a custom-made powder-coated steel base. The three base types to choose from are:

Table base

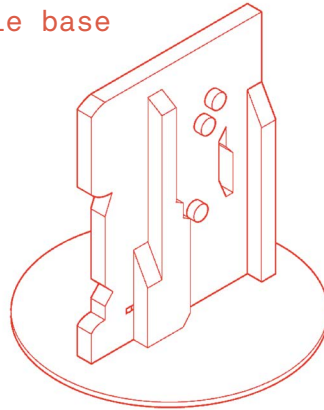

Fold-up base

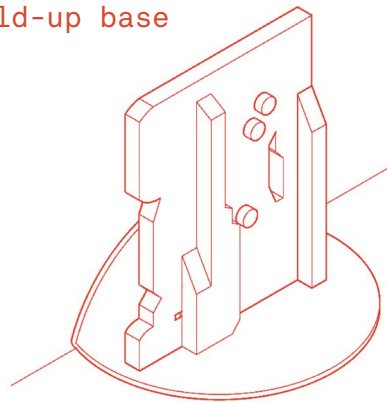

Fold-down base

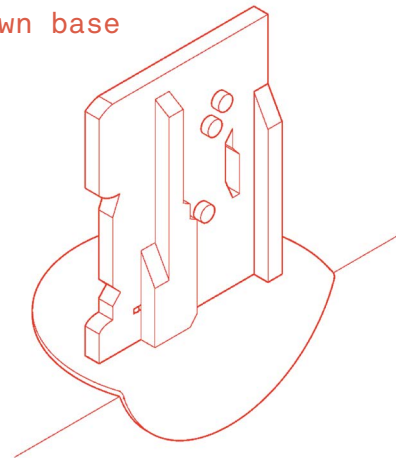

Wall-mount base\*

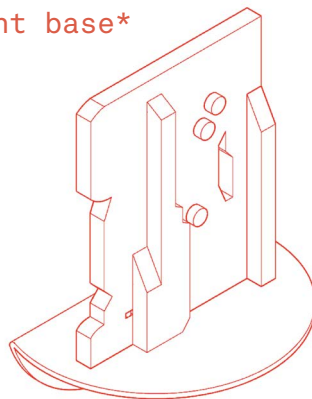

\*Wall-mount bases have concealed fixings.

*Lost Tablet Clémentine, 2021*  
19 x 25 x 4.6 cm  
Reconfigured Lego  
AUD 4200







*Lost Tablet Princess Augusta, 2021*  
19 x 24.5 x 3.3 cm  
Reconfigured Lego  
AUD 4200



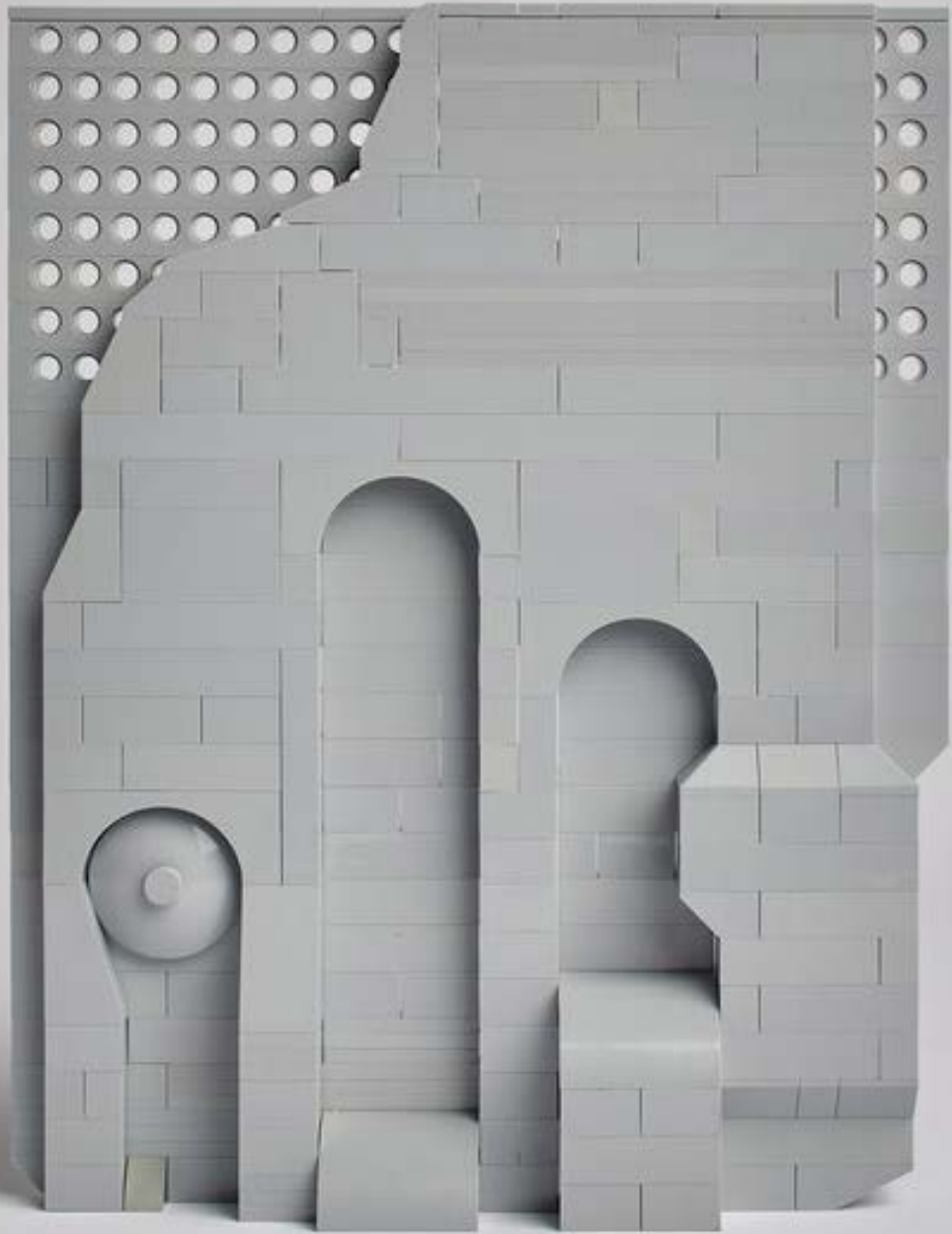



*Lost Tablet Andrea Gail, 2020*  
19 x 24.5 x 2.2 cm  
Reconfigured Lego  
AUD 4200





*Lost Tablet Antonia Graza, 2021*  
19 x 24.5 x 6.4 cm  
Reconfigured Lego  
AUD 4200





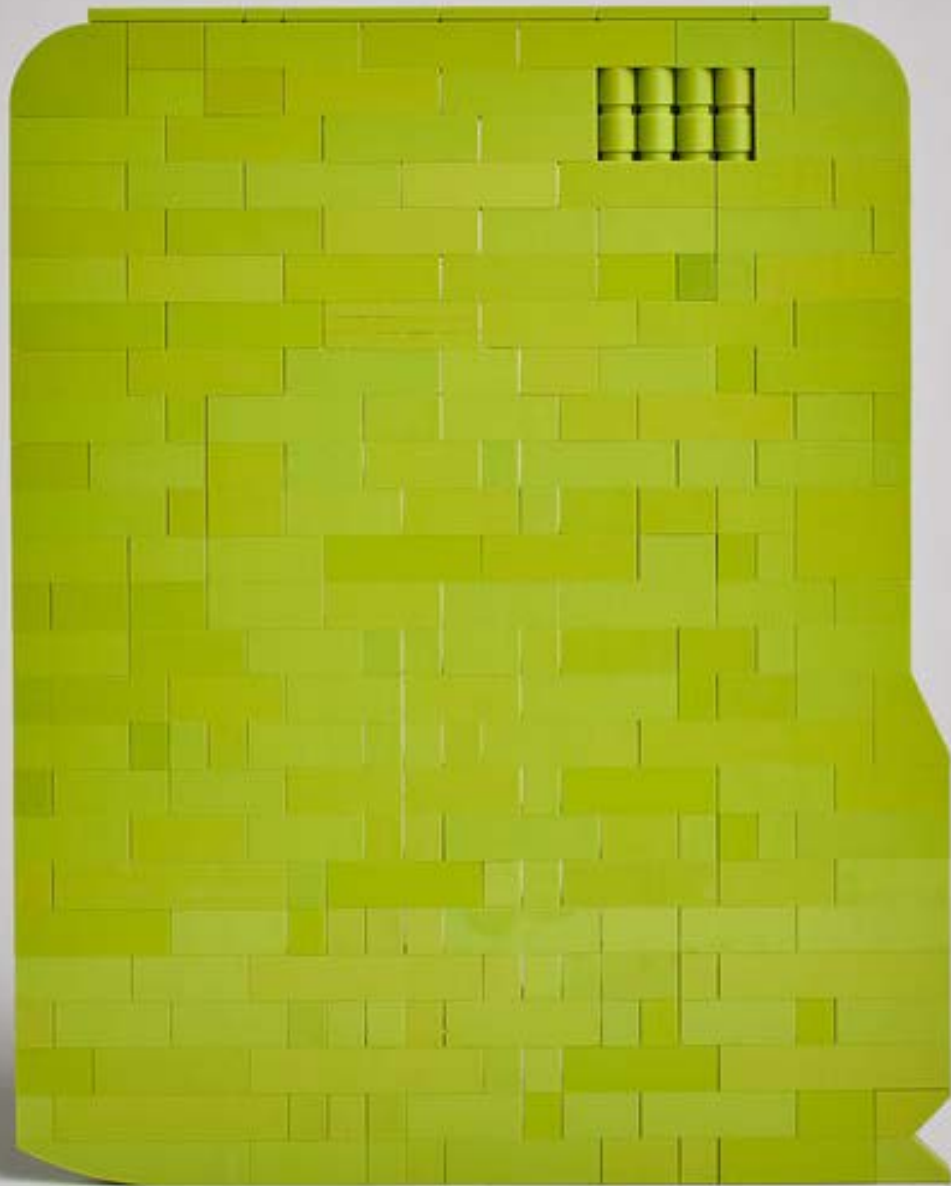

*Lost Tablet Alouete I, 2021*  
19 x 24.5 x 8.3 cm  
Reconfigured Lego  
AUD 4200



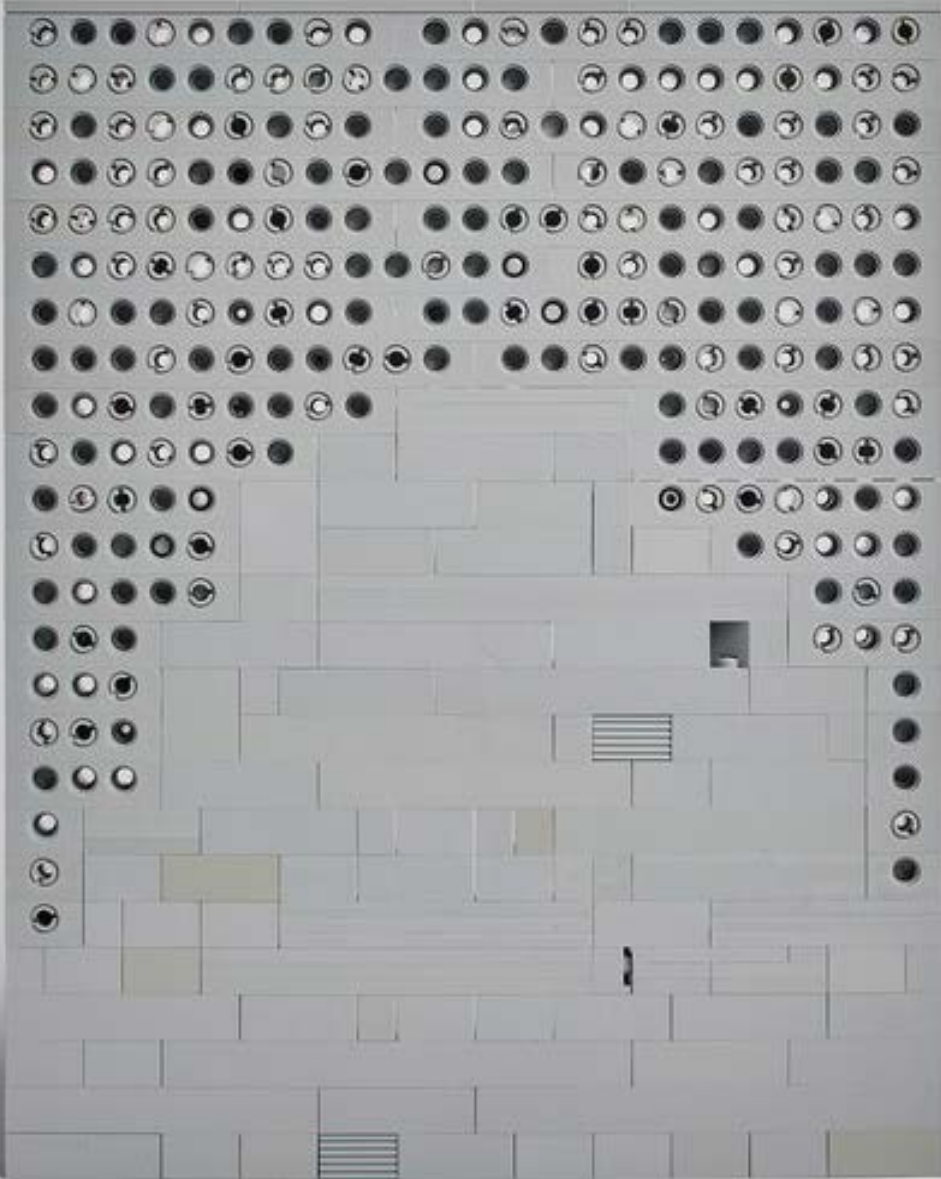

*Lost Tablet Aeolus, 2020*  
19 x 24.5 x 4.9 cm  
Reconfigured Lego  
AUD 4200







*Lost Tablet Amos II, 2021*  
19 x 24.5 x 4 cm  
Reconfigured Lego  
AUD 4200





*Lost Tablet Essaim, 2021*  
19 x 25 x 3.3 cm  
Reconfigured Lego  
AUD 4200







*Lost Tablet Orzel, 2021*  
19 x 25.5 x 4.8 cm  
Reconfigured Lego  
AUD 4200



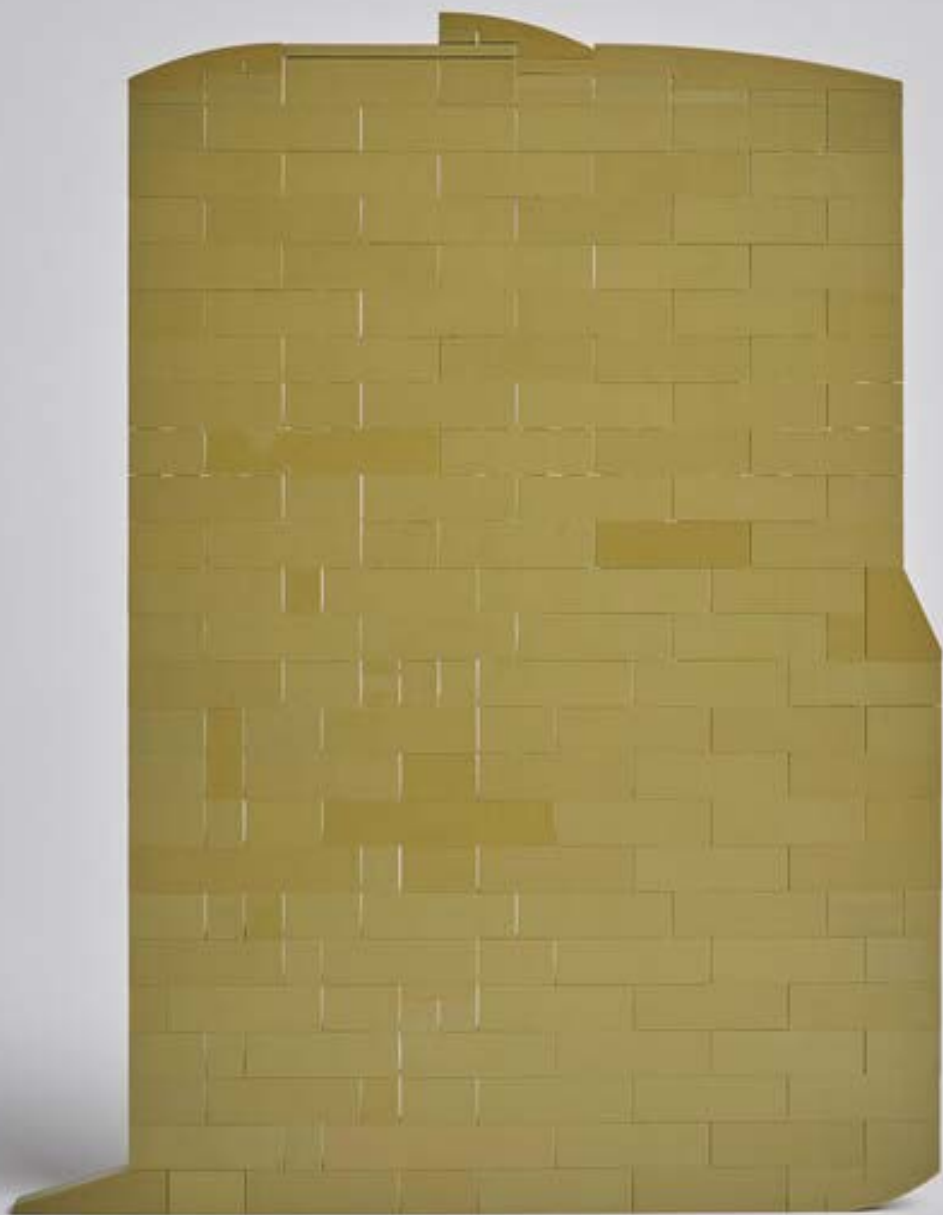

*Lost Tablet Epervier, 2021*  
19 x 24.5 x 3 cm  
Reconfigured Lego  
AUD 4200







The table base comes with the option of either a plinth or hand-blown glass vitrine.\*

\*Plinths and vitrines incur an additional cost of AUD 770.

## Limited Edition Prints

Direct print on aluminium di-bond      AUD 1700

Painted timber frame

Split batten mount

Edition of 2 and 1 artist proof

64.5cm x 50.5cm

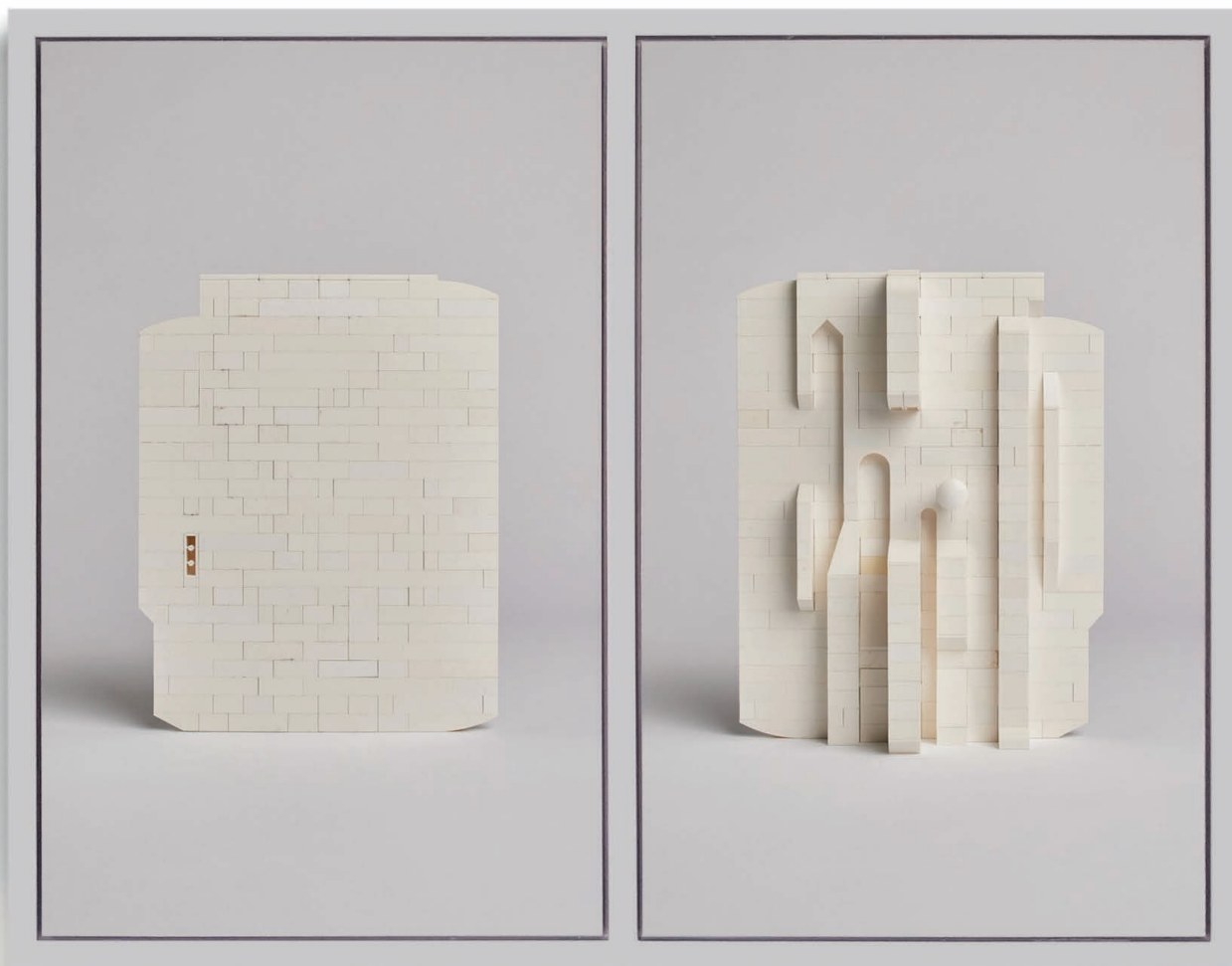

For information about limited edition large format *Lost Tablets* prints  
please visit [losttablets.com/shop](http://losttablets.com/shop)

## Exhibitions

*Lost Tablets* have been exhibited by Kalli Rolfe Contemporary Art, Neon Parc, Sarah Scout Presents and Charles Nodrum Gallery.

They have made appearances at the Quarantine Art Fair, Spring 1883, and Open House Melbourne. *Lost Tablets* are listed with The Artling and Artsy.

Throughout 2023 *Lost Tablets* is exhibiting work at the Alfa Gallery Artsy Exhibit, Miami.

In 2021 *Lost Tablets* were exhibited in the 17th Venice Biennale of Architecture.

## Awards

*Lost Tablets* have been shortlisted for the Lethbridge 20000 Small Scale Art Award, the Architecture Australia 2021 Unbuilt Award, and the 2020 McClelland Small Sculpture Prize.

## More info

For details of all exhibitions, press, awards, and upcoming events please visit [losttablets.com/news](http://losttablets.com/news)

All photography by Peter Bennetts.

## Press

*Lost Tablets* have been reviewed in Broadsheet, Nikkei Asia, Art Edit Magazine, The Artling's Artzine, Newsela, CBD News, the Sydney Morning Herald, Brick Fanatics, The Age, Frizzifrizzi Art and Design Magazine, Present & Correct Blog.

*Lost Tablets* was published in *Out of the Box: A Celebration of Contemporary Box Art*, edited by London based author Tom Buchanan and published by Thames and Hudson.

*Lost Tablets* have been featured on ABC Perth radio and Channel 10's The Project.

## Jan van Schaik

Jan is a practicing architect and artist, an educator and researcher, and creative sector consultant/policy advisor.

[losttablets.com](http://losttablets.com)